

G-eco 50S VERTICAL BALER

ENGINEERING SOLUTIONS FOR THE WASTE & RECYCLING INDUSTRIES

The Gradeall G-eco 50S is a multi-purpose compact vertical baler that can be used to bale a wide range of materials. This single chambered machine creates a compact and neat bale from any type of cardboard or plastic material. The G-eco 50S has been designed, built and assembled by Gradeall International to ensure the highest quality and levels of dependability.

The robust nature in which the G-eco 50S is built ensures a long life span, this coupled with minimal maintenance requirements results in an efficient and cost-effective baling and recycling solution, ideally suited for small retailers or businesses dealing with waste packaging.

- Small footprint with compact dimensions.
- IP55 rated for outdoor use.
- Ready to use with a 240v 13A single phase supply.
- Simple to operate controls.
- Suitable for paper, cardboard or plastics.
- Insert available to bale material into plastic bags.
- Energy efficient, motor only operates when required.



Model	G-eco 50S
Width (mm)	1000
Height (mm)	2175
Depth (mm)	830
Power supply	240v 13A Single Phase
Motor size (Kw)	1.1
Cycle time (Seconds)	40 Maximum
Bale dimensions (mm)	700 x 700 x 500
Bale weight (Kg)	30-60
Machine weight (Kg)	380
Head compaction force (Tonne)	5
Number of bale twines per bale	2
Noise level (dB)	65-70
Loading door height (mm)	846
Loading door opening aperture (mm)	710x474
Recommended working area (mm)	2005x1590

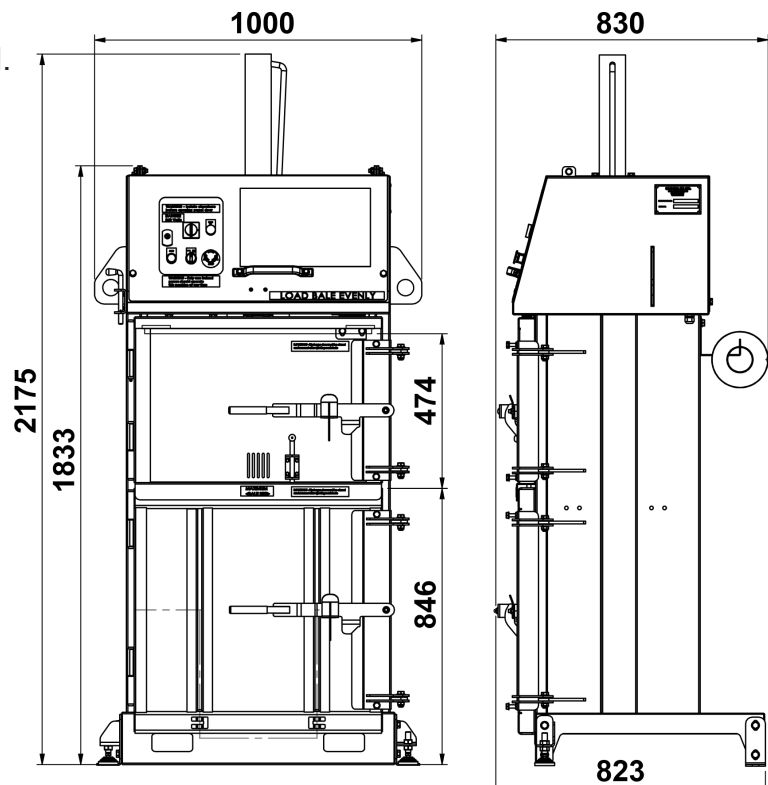

G-eco 50S VERTICAL BALER

ENGINEERING SOLUTIONS FOR THE WASTE & RECYCLING INDUSTRIES

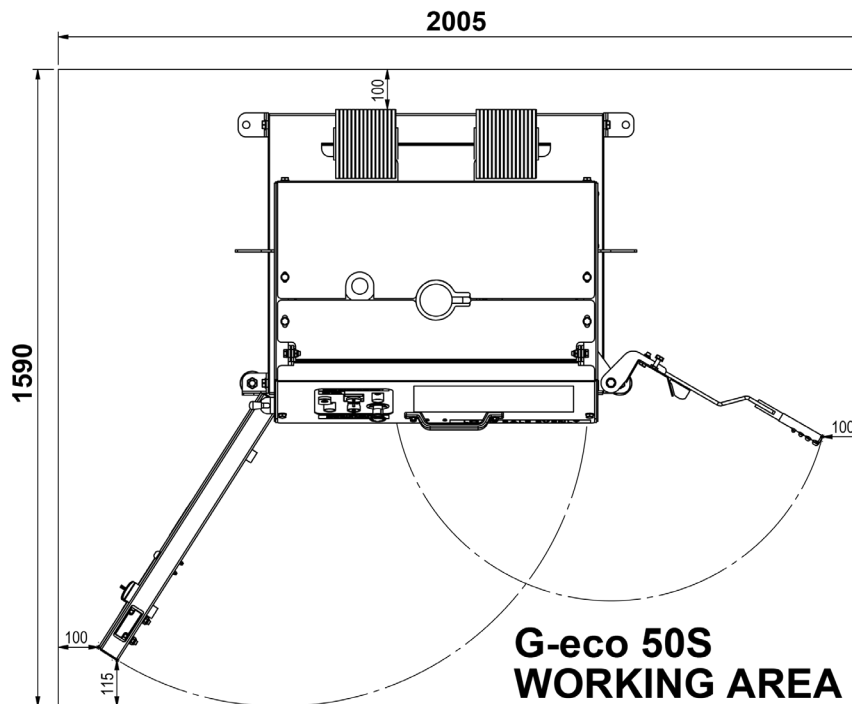

G-eco 50S Optional Extras



Bag Compactor

Bale materials within a plastic bag. Ideal for baling loose materials together and keeping bales dry whilst in storage.



Paint bucket press

Insert to allow the baler to crush paint buckets or metal oil drums.



Bale Trolley

Remove and move bales without any physical strain required.

Also available: Door retainers to hold the doors open, halogen free wiring



Gradeall International Limited
9 Farlough Road,
Dungannon, County Tyrone
Northern Ireland
BT71 4DT



Tel: +44 (0)28 8774 0484
Fax: +44 (0)28 8774 8823
Email: sales@gradeall.com
Stephen: +44 7703 529 008
Alan: +44 7435 764 008



www.gradeall.com