

G-eco 50T MULTIPLE CHAMBER BALER

ENGINEERING SOLUTIONS FOR THE WASTE & RECYCLING INDUSTRIES

The G-eco 50T is a multiple chambered baler that allows the user to load and bale different materials simultaneously. It is suitable for paper, cardboard and soft plastics such as plastic packaging.

The G-eco 50T features a sliding head which contains the hydraulic power pack and ram required to perform the compaction of materials. The moving head slides effortlessly across between chambers to leave one chamber free for loading, whilst the other is producing a bale.

Available with varied numbers of chambers. The double chamber G-eco 50T, three chamber 50-3 and four chamber 50-4. The modular design means that extra chambers are a simple bolt on option.

- Small footprint with compact dimensions.
- IP55 rated for outdoor use.
- Ready to use with a 240v 13A single phase supply.
- Simple to operate controls.
- Suitable for paper, cardboard or plastics.
- Insert available to bale material into plastic bags.
- Energy efficient, motor only operates when required.



Model	G-eco 50T
Width (mm)	1820
Height (mm)	2120
Depth (mm)	920
Power supply	240v 13A Single Phase
Motor size (Kw)	1.1
Cycle time (Seconds)	40 Maximum
Bale dimensions (mm)	700 x 700 x 500
Bale weight (Kg)	30-60
Machine weight (Kg)	560
Head compaction force (Tonne)	5
Number of bale twines per bale	2
Noise level (dB)	65-70
Loading height (mm)	1270
Loading chamber dimensions (mm)	700x500x1090
Recommended working area (mm)	2330x1755

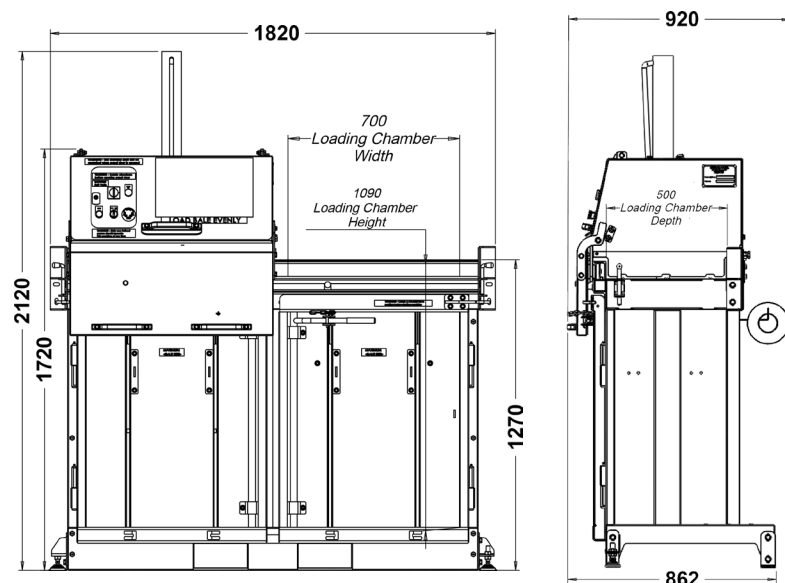

G-eco 50T MULTIPLE CHAMBER BALER

ENGINEERING SOLUTIONS FOR THE WASTE & RECYCLING INDUSTRIES

Optional Extras



Extra chambers can be added to the baler if required. Allowing for more efficient segregation of waste.



Paint bucket press

Insert to allow the baler to crush paint buckets or metal oil drums.



Door retainers

Ideal for outdoor use to prevent wind from swaying the doors when open.

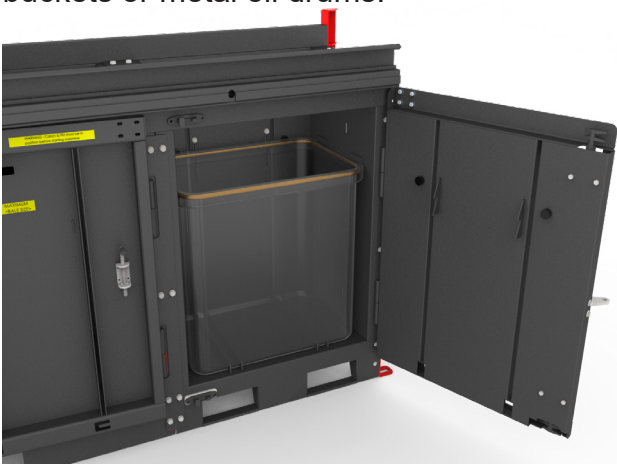

Bag Compactor

Bale materials within a plastic bag, ideal for holding loose materials together.



Bale Trolley

Remove and move bales without any physical strain.

G-eco 50T MULTIPLE CHAMBER BALER

ENGINEERING SOLUTIONS FOR THE WASTE & RECYCLING INDUSTRIES

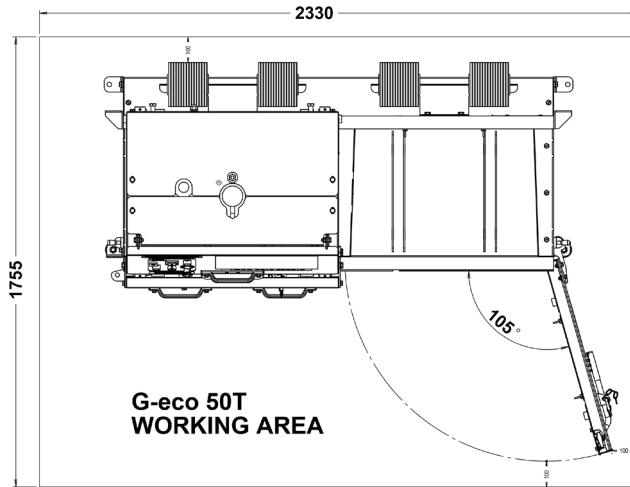

G-eco 50-T Weight
560Kg

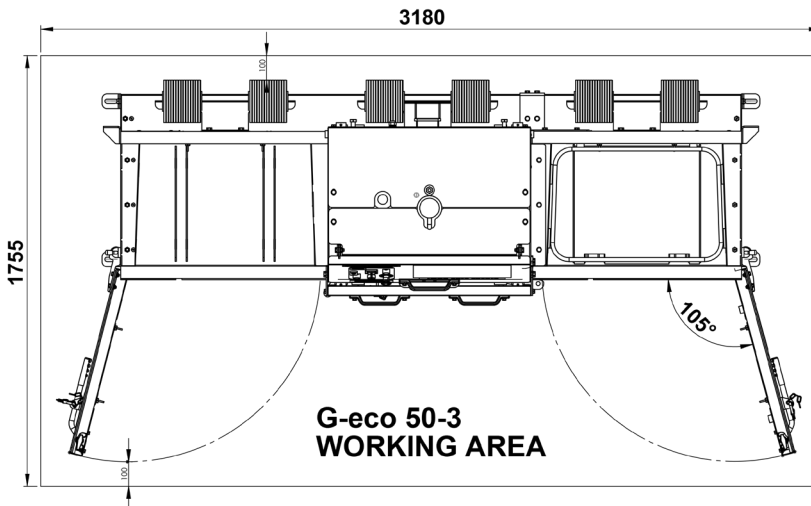

G-eco 50-3 Weight
840Kg

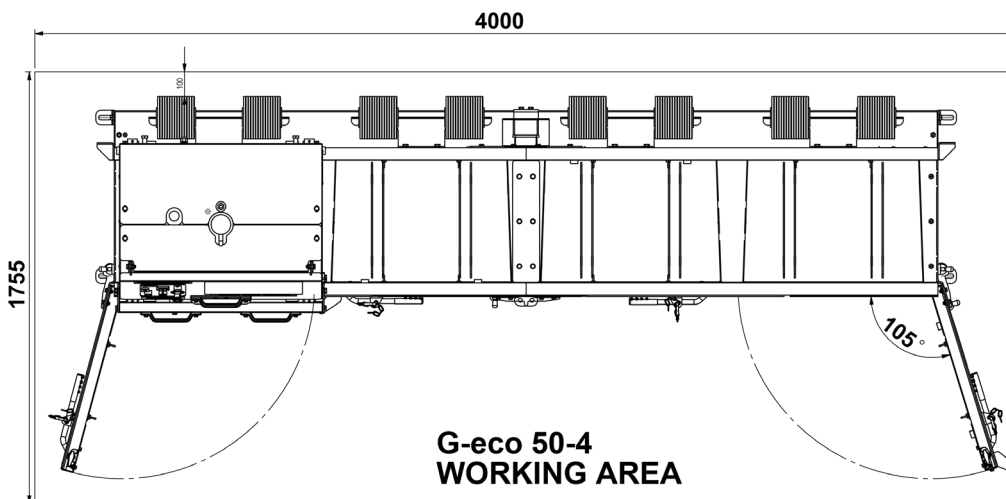

G-eco 50-4 Weight
930Kg