

QUATTRO ALBERI FOUR SHAFT

4
SHAFTS

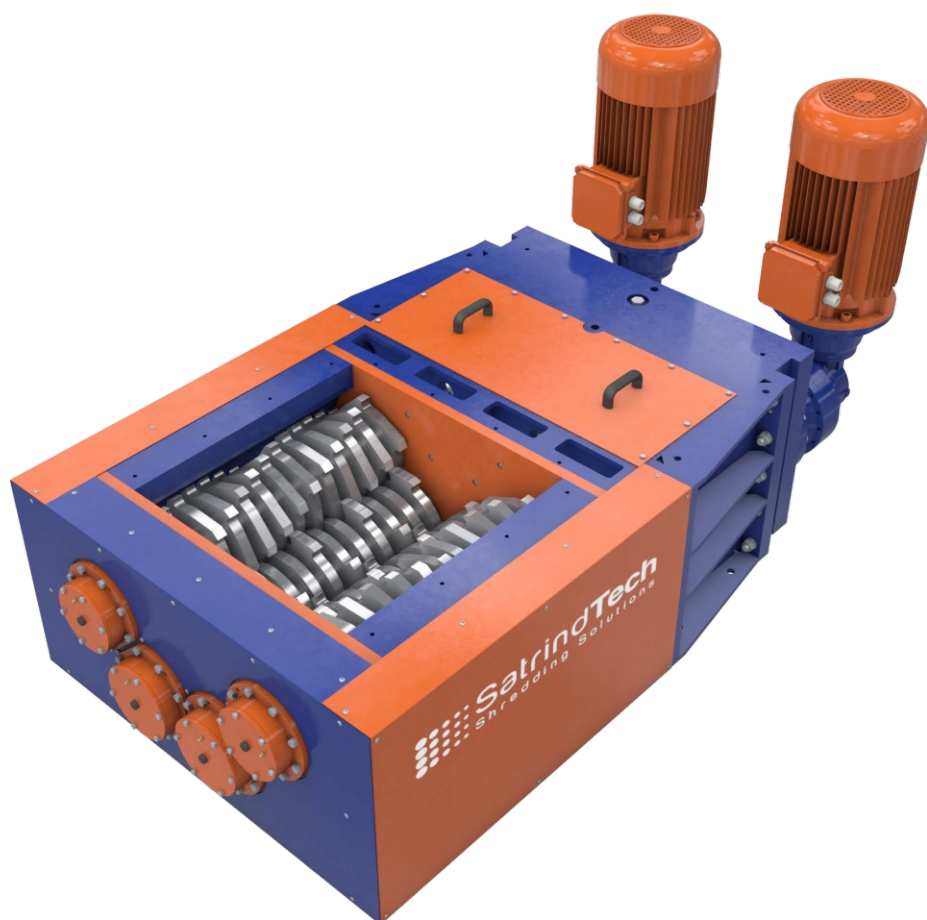

4S/40 4S/60

Modello Model	Potenza Power (kW)	Camera di lavoro Shredding chamber LxW (mm)	Lame da (n.) Blades (pcs)			
			15mm	19mm	29mm	43mm
4S 7/40	2 x 15	698 x 800	46 (C) + 46 (R)	36 (C) + 36 (R)	24 (C) + 24 (R)	16 (C) + 16 (R)
4S 10/40		1044 x 800	-	54 (C) + 54 (R)	36 (C) + 36 (R)	24 (C) + 24 (R)
4S 12/40		1218 x 800	-	-	42 (C) + 42 (R)	28 (C) + 28 (R)
4S 7/60	2 x 22	698 x 800	46 (C) + 46 (R)	36 (C) + 36 (R)	24 (C) + 24 (R)	16 (C) + 16 (R)
4S 10/60		1044 x 800	-	54 (C) + 54 (R)	36 (C) + 36 (R)	24 (C) + 24 (R)
4S 12/60		1218 x 800	-	-	42 (C) + 42 (R)	28 (C) + 28 (R)

(C) = Lama Centrale - Cutting blade

(R) = Lama di Ricircolo - Recirculating blade

Dati Tecnici/Technical Data

Lame - Blades

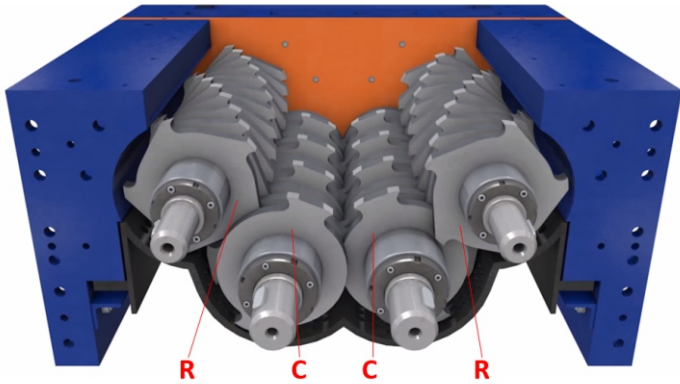

(C) - Lama Centrale - Cutting blade
(R) - Lama di Ricircolo - Recirculating blade

Griglia - Screen

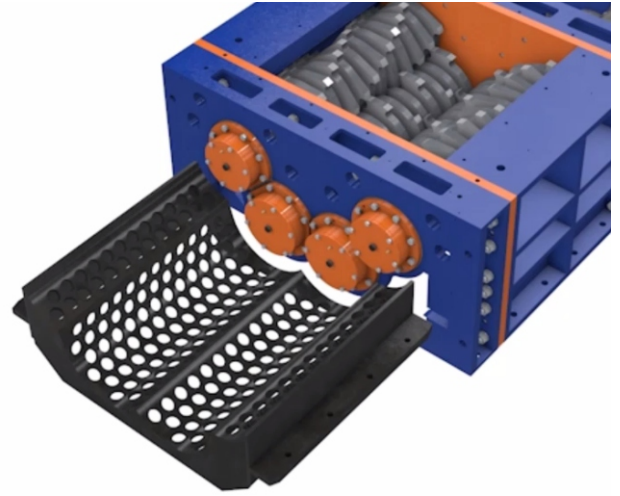

Dimensioni Dimensions

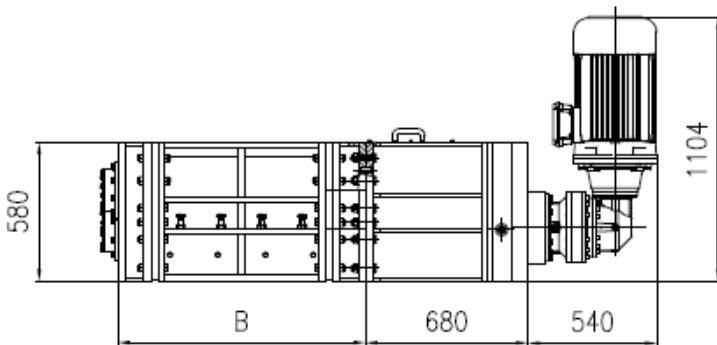

Modello Model	A (in mm)	B (in mm)	C (in mm)
4S 7	698	1038	2320
4S 10	1044	1384	2666
4S 12	1218	1558	2840

Esempi di materiali trattati / Some applications:

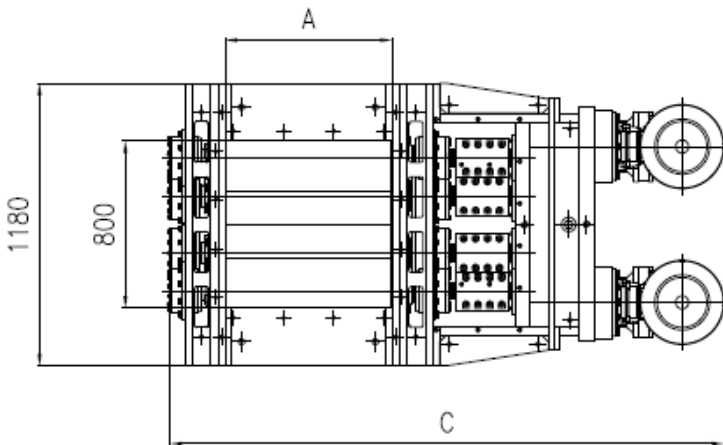

SatrindTech S.r.l.

Via Monfalcone, 122 - 20010 Arluno (MI) - Italy

Tel. (+39) 02 90376683

Fax (+39) 02 90376721

info@satrindtech.com

www.satrindtech.com

