

HERBOLD



The HERBOLD Granulator of the HB Series: Combined Version of Shredder AND Granulator

The advantages of a single-shaft shredder are well known: it is possible to fill a feed hopper which is then gradually emptied by means of a hydraulically operated ram without the assistance of operators: due to its special design, the rotor only "nibbles" at the material that is fed via the hydraulic ram.

Until now it has not been possible to obtain small granule sizes with these shredders: often a 15 or 20 mm-screen has been the lower limit, making intermediate conveying and a secondary granulator necessary in order to achieve smaller granule sizes ranging from 4 to 8 mm and a satisfactory throughput.

Now it is possible in one single size-reduction step with the **HERBOLD granulator of the HB series**. The design of the HERBOLD HB granulator is a combination of a feed hopper and a hydraulic ram with a granulator. Due to the special design of the grinding chamber and the high cutting frequency, it is now possible to transform bales, cutt open film rolls, mingled packs of sprue spiders, but also extremely large and thick-walled purgings into the finished product in one single step.

Also bulk hollow bodies, e.g. whole IBC containers and rainwater collecting basins can be processed with this machine in a particularly economic way. An intermittent feeding of large quantities of material (e.g. a great many of bottle crates) is therefore possible without the necessity of dosed feeding or the risk of jammed material in the grinding chamber. Once the material has been fed and the hopper filled, no operators will any longer be necessary, thus enabling a semi-automatic operation.

The main advantage of this new development is its space-saving design since only one size-reduction step is necessary. In addition, only one size-reduction step also makes cleaning with colour and material changes much easier: there is no intermediate conveying by means of a belt conveyor, where cleaning is extremely difficult. Only one machine will need knife change and maintenance, thus reducing maintenance times and costs.

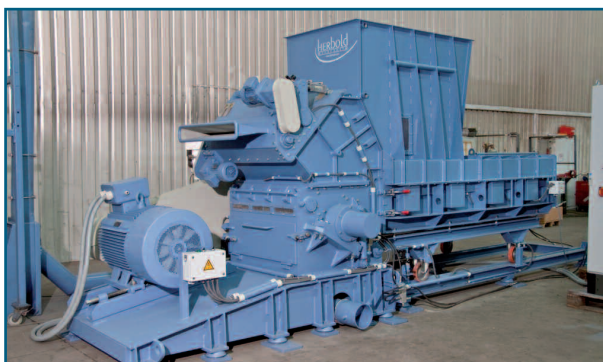

Fig. 1: SML 60/100 HB with additional roller feeding device

Compared to a two-step solution and a granulator fed by gravity, it has also a considerably favourable effect on the energy balance.

The HERBOLD granulators of the SB series, too, show these advantages, well-known characteristics found in all granulators of the HERBOLD product range:

- the placement of the rotor bearings outside prevents fines from penetrating into the bearings and grease into the product
- double-cross cutting action
- fracture-proof welded construction

According to the application, different rotor types are available for the **HB series**. If requested, this granulator can also be delivered as a turn-key package solution with the necessary ancillary equipment, e.g. suction unit with big bag filling station or feeding by automatic lifting/tilting device.

Typical **input material** for the granulator of the **HB series**:



Fig. 2: Cutt open film rolls



Fig. 3: Film bales



Advantages and Features

- Fully automatic operation
- Large infeed opening
- Large feed hopper for feeding whole bales or full boxes of waste.
- One-step size reduction to the desired final size
- Finished product ideal for further processing
- Easy access to the cutting chamber for cleaning works

Applications

Plastics

- Bulk hollow bodies
- Purgings
- Pipes and profiles
- Films
- Post-consumer bottles
- Fibres
- Carpet waste

Wood

Recycling

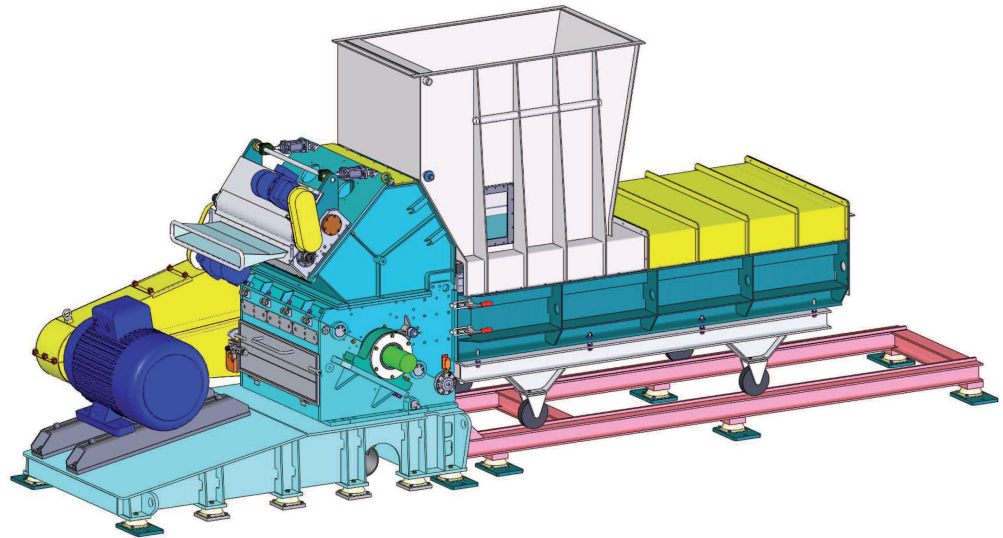

Technical Data		
Type	SML 60/100 HB	SML 60/145 HB
Rotor diameter mm	600	600
inches	24"	24"
Working width mm	1000	1450
inches	40"	57"
Drive kW	45 - 110	55 - 132
HP	60 - 150	75 - 180
Throughput rate* t/h	0.5 - 3.0	0.8 - 4.0
lbs/hr	1100 - 6300	1800 - 9000
Weight kg	4500	5500
lbs	9920	12125

*Capacity depending on screen size, material and rotor type



Our Product Range

- Guillotines
- Shredders
- Hammer mills
- Granulators
- Pulverizing systems
- Washing systems & components
- Plastcompactors/agglomerators

Herbold Meckesheim GmbH

Industriestr. 33
74909 Meckesheim
Postfach 1218
74908 Meckesheim
Deutschland
Tel.: + 49 (0) 6226/932-0
Fax: + 49 (0) 6226/932-495
E-Mail: herbold@herbold.com
Internet: www.herbold.com

Our subsidiary:

Herbold Meckesheim USA Resource Recycling Systems Inc.

130 Industrial Drive
North Smithfield, RI 02896, USA
P.O. Box 239
Slatersville, RI 02876, USA
Tel.: +1 401 597/5500
Toll-free (US/CDN): +1 888/612 RRSI (7774)
Fax: +1 401 597/5535
E-Mail: info@herboldusa.com
Internet: www.herboldusa.com